

Scale drawings

Standard version

- seal gas supply directly on the sensor
- sensor position on carrier rail steplessly variable

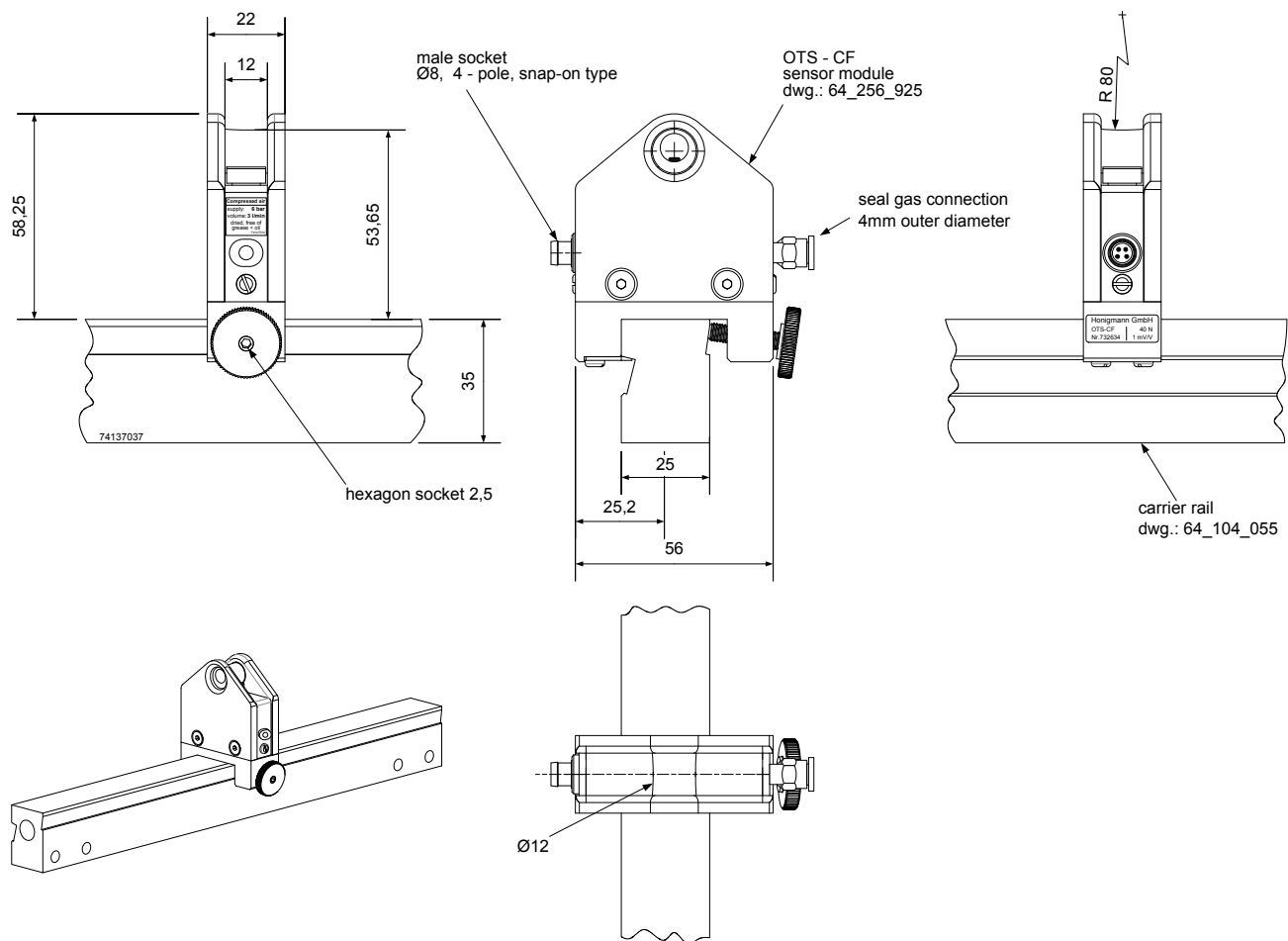

All dimensions in mm

Dimensions of the carrier rail are exemplary and custom-specific.

OTS-CF

On-line Tension Sensor for Carbon Fibers



Special version

- central seal gas supply on the carrier rail
- sensor position on carrier rail in fixed intervals

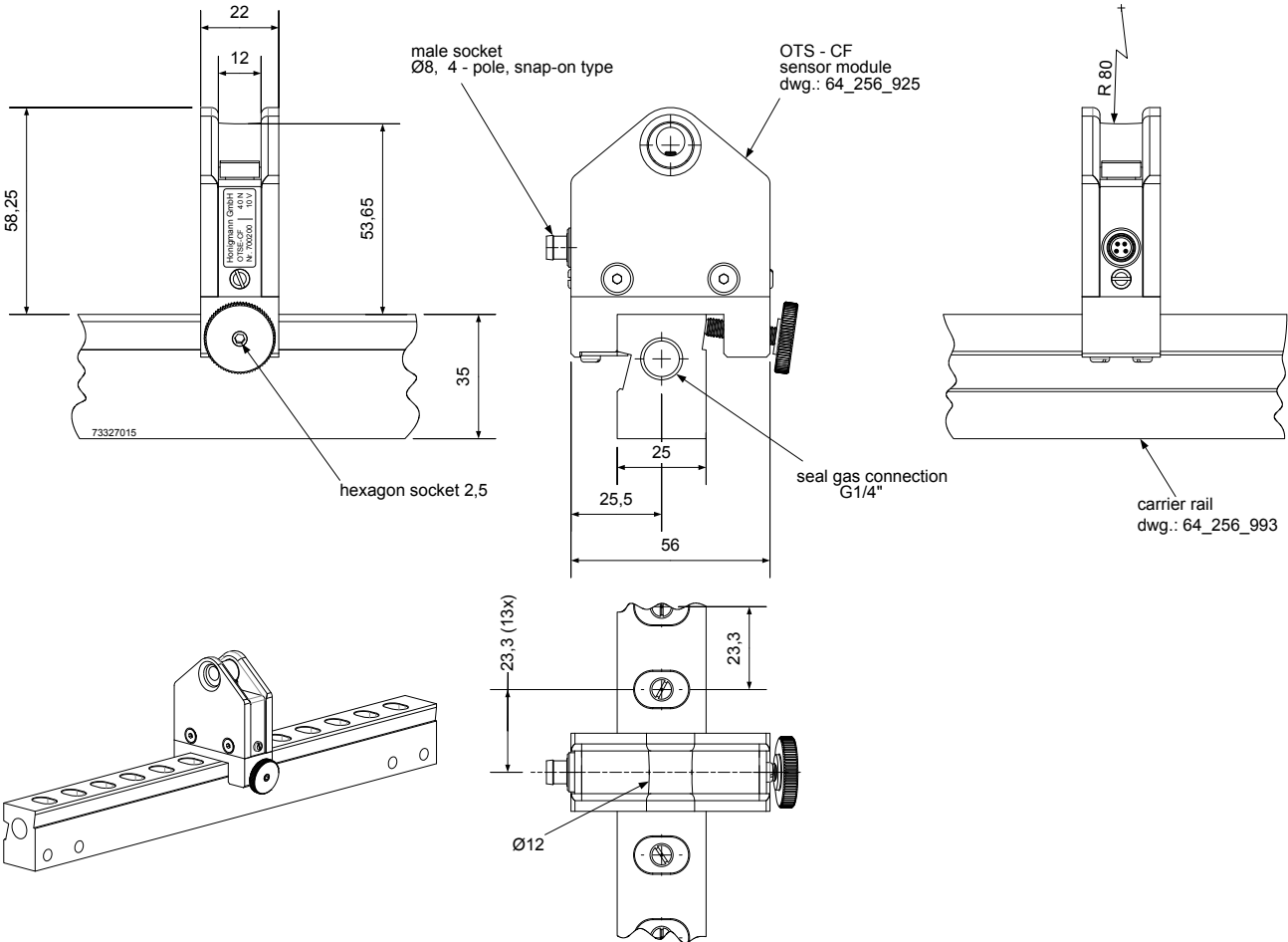

All dimensions in mm
 Dimensions of the carrier rail are exemplary and custom-specific.

Rated measuring ranges

Nominal force [N]									
40									

The measuring range of the sensor begins at the force's zero point.
Nominal forces differing from the list are available.

Calculating the nominal force

The resulting force depends on the wrap angle at the measuring position.

$$F_R = 2 \cdot F_Z \cdot \sin \frac{\alpha}{2}$$

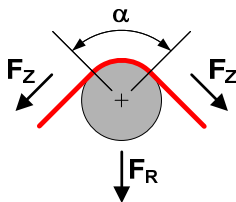

α: wrap angle
Fz: tension
FR: resulting force

Example

wrap angle α	resulting force FR
5°	0,09 • Fz
10°	0,17 • Fz
20°	0,35 • Fz
30°	0,52 • Fz

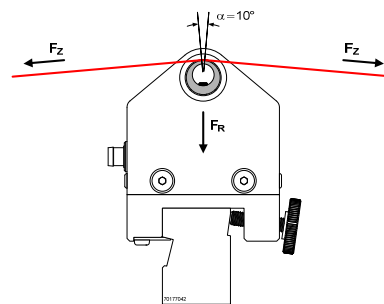

α = 10°, Fz = 40N
The resulting force FR is 6,8N.

Order code

	OTS - CF - 40 - S
Type	
Design	
Nominal force [N]	
Connection	S: with male socket

Options

- Seal gas supply directly on the sensor
- Central seal gas supply on the carrier rail

Scope of supply

- Sensor according to scale drawing
- Flow control valve DV3L6 (at option seal gas supply directly on the sensor)
- Pneumatic tube, 2m long

Accessories

- Connection cable with mating connector
- Carrier rail

Technical data

Nominal force (F_N)	N	40
Rated output	mV/V	1
Rated output tolerance	%	< $\pm 0,2$
Accuracy class		0,5
Excitation voltage max.	V	12
Reference excitation voltage	V	10
Input resistance	Ω	350 ± 3
Output resistance	Ω	350 ± 1
Isolation resistance	GΩ	> 10
max. wrap angle	°	60
Nominal temperature range	°C	5 to 50
Operational temperature range	°C	-10 to 50
Storage temperature range	°C	-30 to 70
Reference temperature	°C	23
Temperature influence per 10 K		
- on the zero point (TK0)	% F_N	< $\pm 0,2$
- on the calibration (TKC)	% F_N	< $\pm 0,15$
Creep after 30 minutes	% F_N	< $\pm 0,05$
Linear output signal up to	% F_N	approx. 125
Mech. overload protection takes effect at	% F_N	approx. 140
Overload protected ¹	% F_N	> 1000
Typ. deflection at nominal force	mm	0,07
Typ. natural frequency of the sensor	kHz	1,5
Weight	g	approx. 160
Connector	male socket, \varnothing 8 mm, 4-pole, snap-on type gold-plated contacts	
Sensor housing	aluminium	
Protection class	IP54 in conjunction with seal gas	

¹ radial incoming force without additional bending or tilting moment

Electrical connections

Connector pin assignment

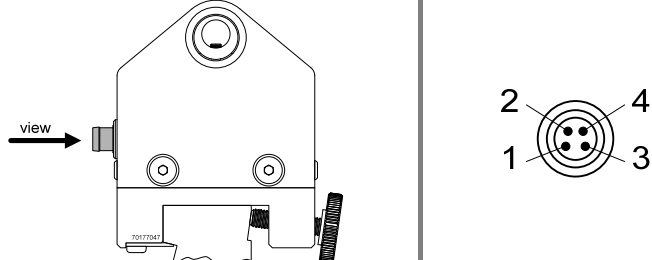

1	+ U _{Br}	Excitation
2	- U _{Br}	
3	+ U _{Sig}	Output
4	- U _{Sig}	

73327016

Connecting cable colour assignment

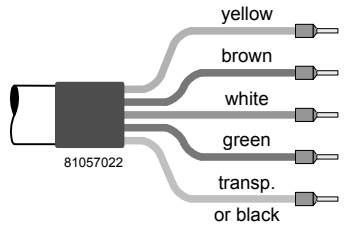

+ U _{Br}	Excitation
- U _{Br}	
+ U _{Sig}	Output
- U _{Sig}	
Shield (not connected to housing)	

Mating connector: female cable connector, angled or straight, Ø 8 mm, 4-pole, gold plated contacts, snap-on type

Seal gas connection

if directly supplied on the sensor

Flow control valve

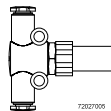

factory-adjusted,
3l/min at 6bar

DV3L6

Seal gas supply



The seal gas must be dried, free of grease + oil.



- Input pressure: **6bar**
- Rated volume flow: **3l/min**

Technical design subject to change without prior notice. © 2021 by Honigmann

Honigmann Industrielle Elektronik GmbH • In den Weiden 20 • 58285 Gevelsberg • ☎ +49-2332-55115-0 • 📠 +49-2332-55115-99