

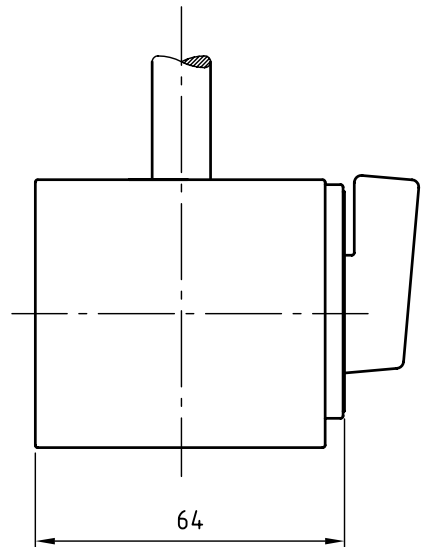

260

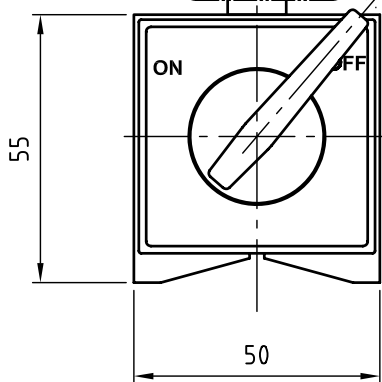
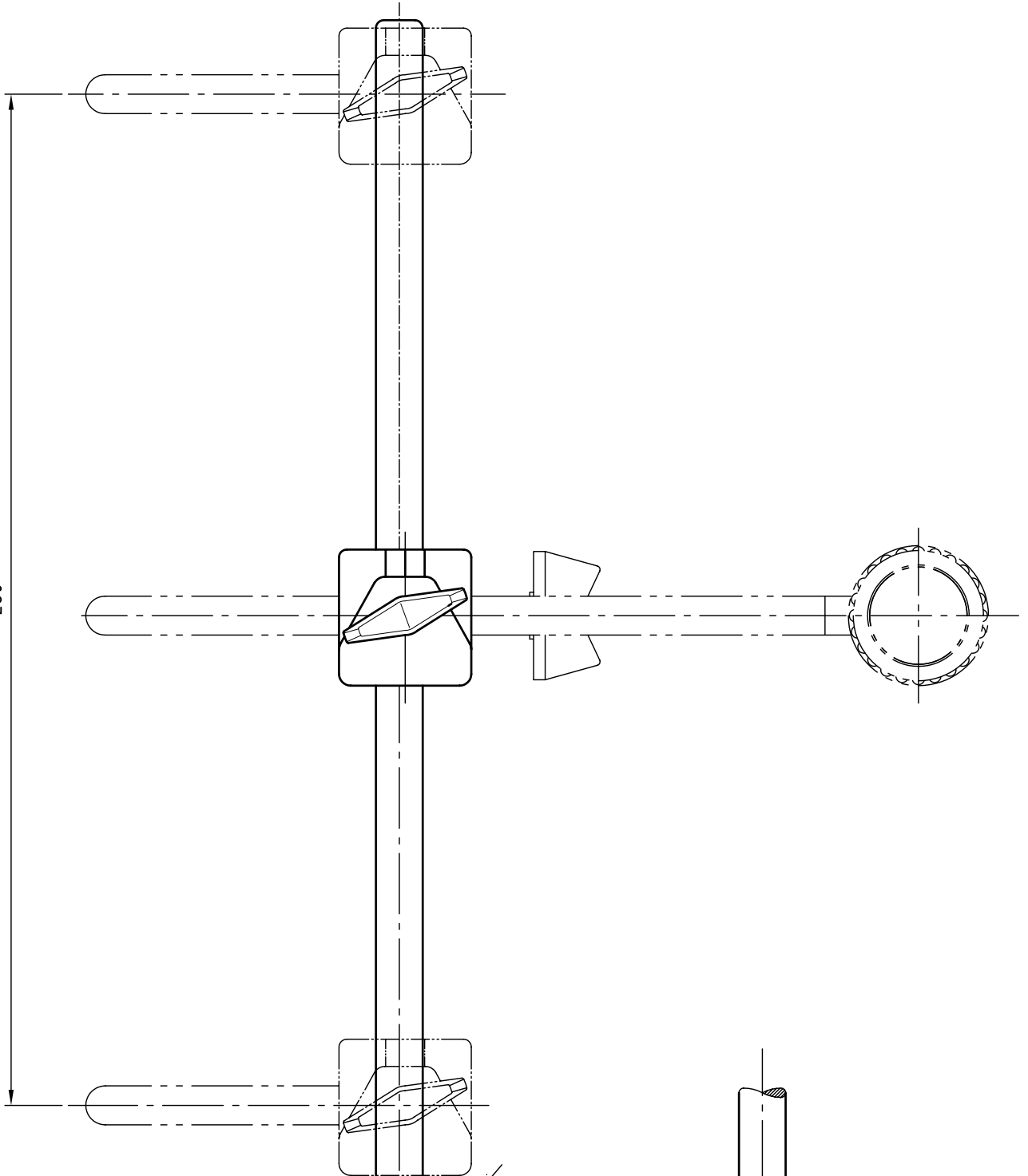

Schutzvermerk nach DIN 34 beachten		Allgemeintoleranz DIN 7168-f	Pr.Nr.	Maßstab 1:1.6 /A4	Mod.: Spann.	
				Werkstoff		
		Datum	Name	Magnetfußstativ mit Spannvorrichtung		
		Erst. 07.07.05	ch			
		Gepr.				
		Norm				
		I.St. 07.07.05	ch	Z.-Nr.: K 490434		
		 Honigmann GmbH Industrielle Elektronik 42289 Wuppertal				Blatt 1
Zust.	Änderung	Datum	Name	Urspr.	Ers. für Z.Nr.:	ers. durch Z.Nr.:
						v. 1Bl.